

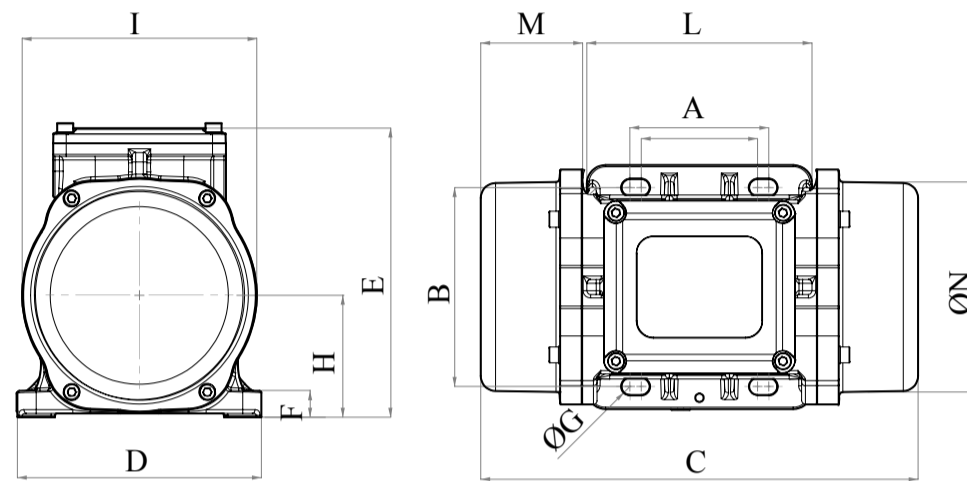

# MVE 90/15E-20A0 (EE40009020A0JA0000)

3 PH - 4 poles - 1500 RPM - 220-240/380-415 V - 50 Hz





Working moment [Kg*cm]	Unbalance [Kg*cm]	Centrifugal force [Kg]	Nominal voltage [V]	Input power [kW]	Current [A]	Power Factor	Ia/In
5,97	2,99	75	220-240/380-415	0,07	Δ 0,54 Y 0,31	0,33	2,2



OVERALL DIMENSIONS (mm)													
Weight [Kg]	A	B	G	Holes number	C	D	E	F	H	I	L	M	N
7,4	62-74	106	9	4	233	130	154	15	65	125	120	54	112

TECHNICAL FEATURES						
Type of grease	Greased for life	Screw	Washer	Clamping torque [Nm]	Cable type	Cable gland
/	Yes	M8	8,4 x 16 mm	23	4G2.5 80°C	M20 80°C

BEARINGS			
Type	Life 100%	Life 80%	Life 50%
6302 2Z	>100000	>100000	>100000

CERTIFICATION	
ATEX II2 D Ex tb IIIC T135°C Db IP66 IECEx Ex tb IIIC T135°C Db IP66 CLASS II DIV.2 GROUP F,G T4 Ex tb IIIC Tx Db IP66 CONFTO UL1004-3, UL1004-1, UL 60079-0, UL60079-31 CERT. CSA C22.2 No.100, CSA C22.2 No.77, CSA C22.2N.60079-0, CSA C22.2N.60079-31 T.Amb -20/+40°C	     

REV.0-n/a