

1 PH - 2 poles - 3000 RPM - 230 V (1PH) - 50 Hz

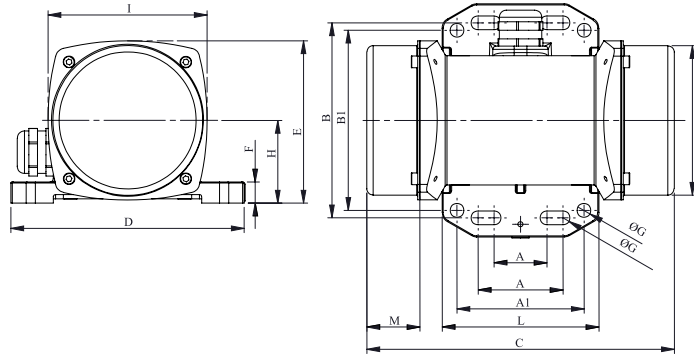



| Working moment [Kg*cm] | Unbalance [Kg*cm] | Centrifugal force [Kg] | Nominal voltage [V] | Input power [kW] | Current [A] | Power Factor | Ia/In |
|------------------------|-------------------|------------------------|---------------------|------------------|-------------|--------------|-------|
| 0,4 | 0,2 | 20 | 230 (1PH) | 0,04 | 0,12 | 0,45 | |



| OVERALL DIMENSIONS (mm) | | | | | | | | | | | | | | | |
|-------------------------|-------|-----|----|-----|-----|--------------|-----|-----|----|----|----|----|----|----|----|
| Weight [Kg] | A | A 1 | B | B 1 | G | Holes number | C | D | E | F | H | I | L | M | N |
| 2 | 25-40 | 60 | 92 | 85 | 6,5 | 4 | 145 | 110 | 76 | 10 | 39 | 75 | 74 | 25 | 70 |

| TECHNICAL FEATURES | | | | | | |
|--------------------|------------------|-------|----------|----------------------|--------------|-------------|
| Type of grease | Greased for life | Screw | Washer | Clamping torque (Nm) | Cable type | Cable gland |
| / | Yes | M6 | 6,5 x 10 | 5 | 3Gx0.75 80°C | M16 80°C |

| BEARINGS | | | |
|----------|-----------|----------|----------|
| Type | Life 100% | Life 80% | Life 50% |
| 6200 ZZ | >100000 | / | / |

| CERTIFICATION | |
|--|---|
| ATEX II2 D Ex tb IIIC T135°C Db IP66 IECEx Ex tb IIIC T135°C Db IP66 CLASS II DIV.2 GROUP F,G T4 Ex tb IIIC Tx Db IP66 CONF.TO UL1004-3, UL1004-1,UL 60079-0,UL60079-31 CERT. CSA C22.2 No.100,CSA C22.2 No.77, CSA C22.2N.60079-0,CSA C22.2N.60079-31 T.Amb -20/+40°C |      |

REV.1-24/07/2018